

Order Code: 100015881

Mobile Stand L20PNSR780MEU

Mobile mounting solution

For handling of mobile visualization, the L20PNSR780MEU mobile stand delivers with modern style.

The L20PNSR780MEU Mobile Stand offers the most complete mobile solution for Sharp and NEC large format and interactive displays. Designed exclusively for Sharp & NEC displays, durable swivel wheels provide easy maneuverability over various flooring surfaces and through doorways. Two locking wheels ensure complete stability wherever the stand is placed. In addition, the continuous tilt and height adjustment assures the display will be positioned at the ideal viewing angle for the viewing audience and the meeting moderator or presenter.



Benefits

- **Mobile stand** – for large format display sizes 50” to 98”
- **Easy maneuvers** – on four 4” (102mm) swivel wheels, two locking wide wheel base increases the amount of work space and reduces tripping in front of the display
- **Integrated cable management** – for clean and professional installation.
- **Vertical adjustment**
- **Neat and tidy solution** – smart and hardwearing black powder coat finish.

Technical Specifications

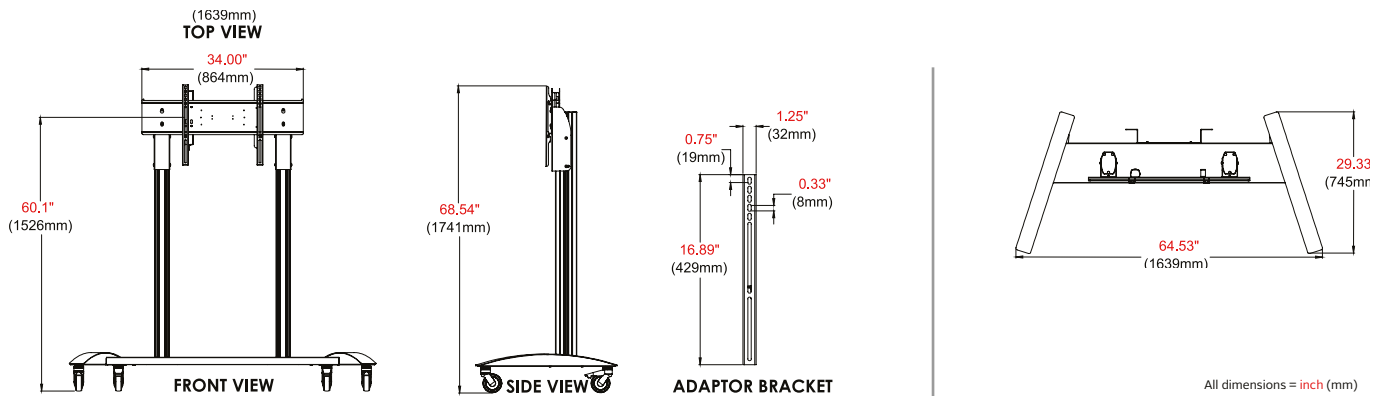

PRODUCT INFORMATION	
Product Name	L20PNSR780MEU
Order code	100015881
Load capacity [kg]	82
Recommended display size	50" - 98"
VESA pattern	max. 800 x 400
Product weight [kg]	45
Shipping weight [kg]	51.6
Packaging dimensions (WxHxD) [mm]	1,212 x 978 x 276
Colour	Black
Warranty	5 years
Supported displays	All Sharp and NEC large format displays from 50" to 90" Exception: Sharp PN-L862B, NEC CB861Q and C981Q SST
For additional pictures and Solutions overview, visit www.sharpnecdisplays.eu for details.	

Sharp NEC Display Solutions Europe GmbH

Landshuter Allee 12-14, D-80637 München
 infomail@sharpnec-displays.eu
 Phone: +49 (0) 89 99 699-0
 Fax: +49 (0) 89 99 699-500
www.sharpnecdisplays.eu