



- UFT (Ultra Fine Touch) Technology
- myViewBoard™ digital whiteboard software
- Dual-pen writing with 3mm/8mm diameter pen tips
- Ambient Light Sensor
- ENERGY STAR® certified

The ViewBoard® IFP30 series embraces UFT (Ultra Fine Touch) Technology to offer more precise writing and faster processing time than traditional IR panels. 2mm height sensitivity increases writing accuracy while allowing for dual-pen annotation with both 3mm & 8mm diameter pens. It's also incredibly responsive, distinguishing the different touch diameters among pens, fingers and palms to avoid false strokes. In addition, the IFP30 series is integrated with myViewBoard™ digital whiteboard software to provide collaboration on the go, and is further complimented by native casting including Miracast, Airplay, and Chromecast. Interactive whiteboards are becoming commonplace. The IFP30 series is the solution for schools and workplaces of all sizes and considerations.

## UFT Technology

Ultra Fine Touch Technology produces a lag-free, pen-on-paper writing experience. Writing accuracy is greatly improved and student-teacher interaction flows more naturally thanks to real-time response rates, dual-pen recognition and our new 3mm tipped pens.

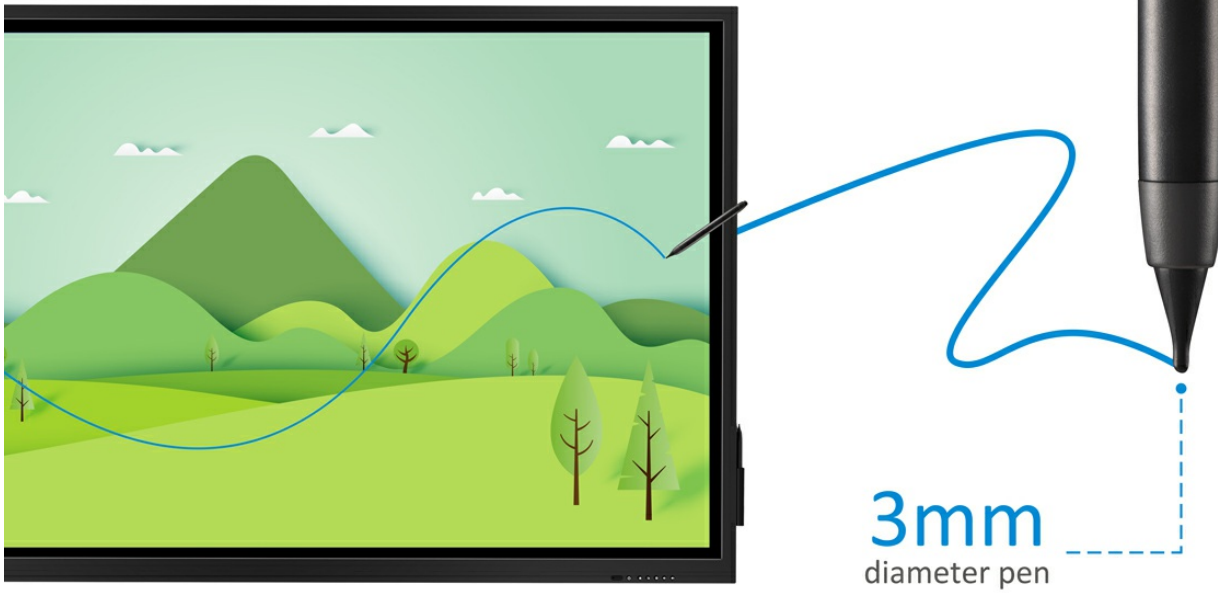

## Dual-Pen

Automatically detect pen diameter (8mm & 3mm) and write simultaneously with different colours and thicknesses.



## Full Native Performance on Android

Built-in myViewBoard™ digital whiteboard software to collaborate on the go.



## Wireless Content Sharing

Content sharing with built-in ViewBoard® Cast software.



## Environmental Sustainability

ENERGY STAR certified for increased energy efficiency.

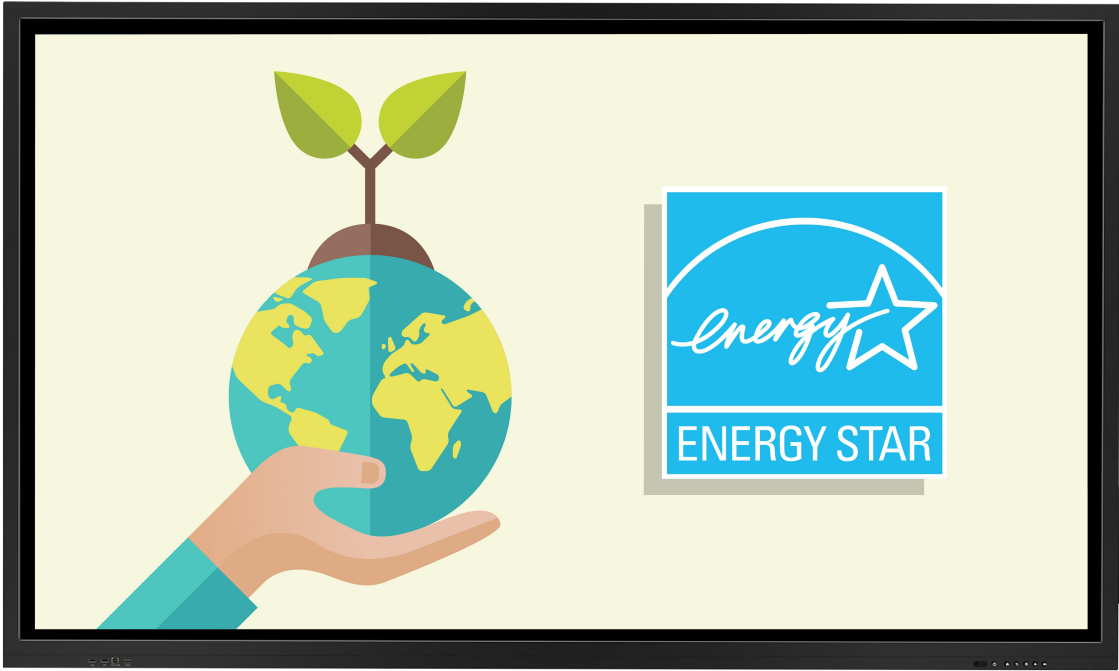

## Ambient Light Sensor

Automatically adjust the brightness to relieve eye strain.



## Slot-in PC

Intel OPS PC allows for efficient deployment and easy maintenance (Optional).

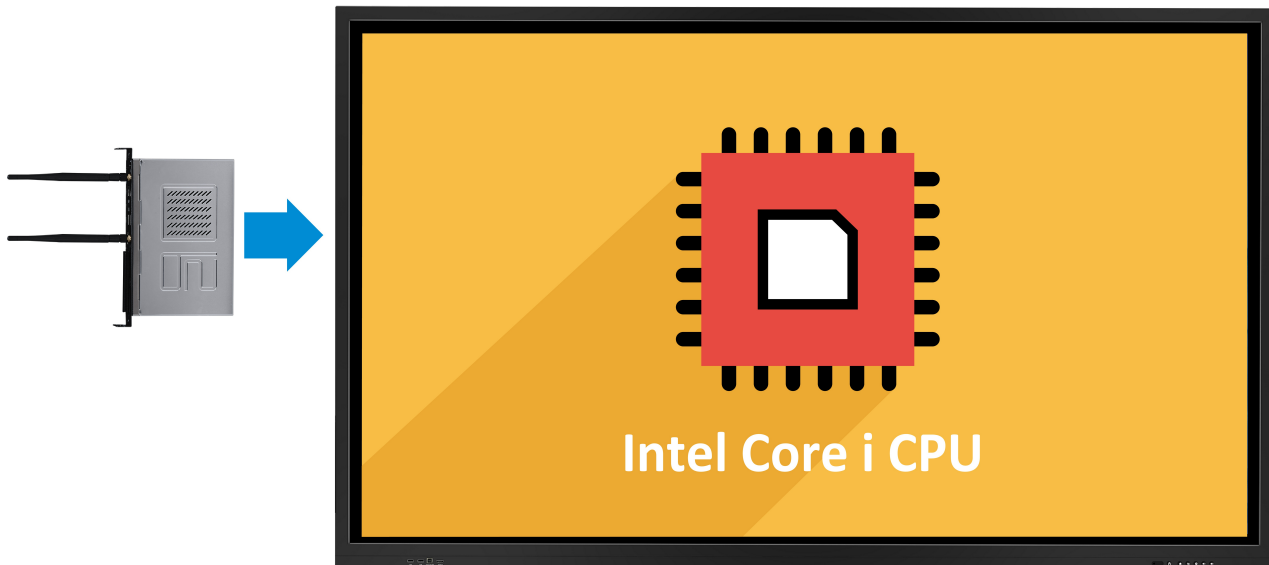

## I/O Ports

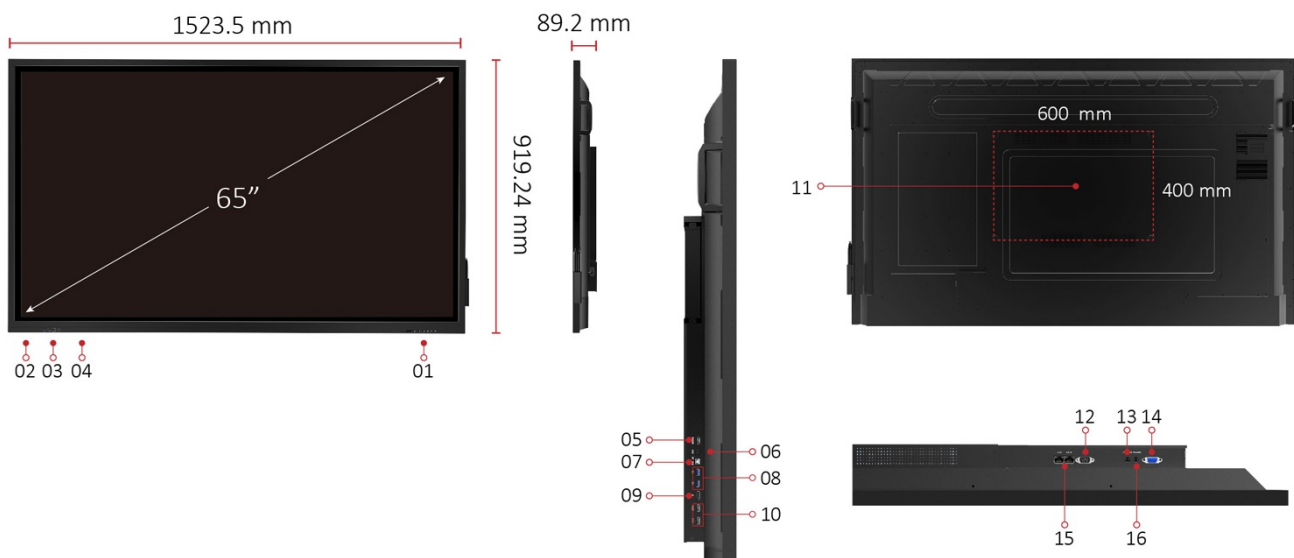

1. CONTROLS PANEL
2. USB X 2
3. TOUCH USB
4. HDMI IN
5. HDMI OUT
6. SPDIF OUT
7. TOUCH USB
8. USB X 2
9. DISPLAY PORT IN
10. HDMI IN X 2
11. VESA® WALL Mount 600x400 mm
12. RS232 IN
13. AUDIO OUT
14. VGA IN
15. LAN X 2

## Technical Specifications

---

<b>Display</b>	Panel Size	65"
	Type/Tech	IPS/V-by-one
	Display Area (mm)	1428.48*803.52mm
	Aspect Ratio	16:9
	Native Resolution	4K60hz
	Colours	10 bits
	Brightness	360(Typ.) 320(min.)
	Contrast Ratio	1200:1
	Response Time	6ms(Type)
	Viewing Angles	H = 178, V = 178 typ.
	Backlight Life	30,000hr(min)
	Surface Treatment	Hardness: 7H Costing: AG coating Thickness: 4mm
	Bezel	29/29/29/49.7mm(btm.)
	Orientation	Landscape
<b>Platform</b>	Processor	ARM Cortex-A73*2 + Cortex-A53*2 1.5Hz
	RAM	3GB DDR4
	Storage	16GB
<b>Touch</b>	Type/ Tech	IR Recognition
	Touch Resolution	32767W*32767D
	Touch Point	20 points 10 writing
<b>INPUT</b>	HDMI	Front*1 Rear* 2 All ports HDMI2.0
	RGB / VGA	1
	DisplayPort	DP1.2*1
	Audio	PC audio in (3.5 mm)*1
	RS232	x1
	OPS	1
	<b>OUTPUT</b>	HDMI
Audio		3.5mm Earphone Out *1, SPDIF*1
SPDIF		x1
<b>LAN</b>	RJ45	*2 10M/100
	<b>USB</b>	Type A
Type B		For touch (Front*1, rear*1))

<b>SPEAKERS</b>	<b>SPEAKERS</b>	15WX2
<b>Camera plate on top for screw-in webcam installation</b>	Camera plate on top for screw-in webcam installation	yes
<b>COMPATIBILITY</b>	RGB PC/HDMI PC HDMI DisplayPort	VGA: 1080p HDMI: 4K 3840x2160 3840x2160
<b>Embedded OS</b>	Embedded OS	OS 8.0 Resolution: 1080p
<b>Power</b>	Voltage Consumption	PB model: 100-240VAC +/- 10% Wide Range On:129W(Typ.) Off: <0.5W
<b>ERGONOMICS</b>	Wall Mount (VESA® )	600 x 400
<b>OPERATING CONDITIONS</b>	Temperature (° C) Humidity	0°C to 40°C 20% ~ 80% RH Non-Condensing(working)
<b>DIMENSIONS (W x H x D)</b>	Physical (inch / mm) Packaging (inch / mm)	1523.5*919.24*89.2(mm) 59.98*36.19*3.51(inch) 1660*1045*245(mm) 65.4*41.1*9.6(inch)
<b>WEIGHT</b>	Net (lb / kg) Gross (lb / kg)	97.4lb/44.2kg 126.8lb/57.5kg
<b>REGULATIONS</b>	<b>REGULATIONS</b>	EMC/CE-EU CB-EU/IEC62368 RoHS Green BOM & RoSH DoC REACH WEEE (Doc & Disassembly report) ErP EAC(local apply) UKrSEPRO(local apply) BIS-India
<b>Energy Star version</b>	Energy Star version	YES
<b>EEL rating</b>	EEL rating	A
<b>PACKAGE CONTENTS</b>	<b>PACKAGE CONTENTS</b>	1. US/EU/UK/AU power cord 3M, no PE bag 2. QSG 3. Compliance statement 4. HDMI cable 3M*1



5. Touch USB cable 3M \*1
6. Touch PEN \*2. Extra tip: Thick\*2, thin\*1
7. Remote control with AAA batteries (VS version)
8. Webcam plate with screws pack
  - a. Need to compatible with Logi CC4000e)
  - b. Add screw holes on top of the frame
9. Pen tray\*1 (two pen, detachable, mount for both side)
10. Wall mount screws

---

Compatible Slot-in PC

Compatible Slot-in PC

VPC12 series

---

## **ViewSonic® Limited Warranty**

---

ViewSonic provides customers with the security of a manufacturers warranty against defected products. The type and duration of the applicable warranty service varies by product type, country of purchase and can also vary on an individual basis according to customer requirements agreed at time of purchase. The warranty will expire after the end of the warranty period.

---

For more product information, visit us at **[www.viewsoniceurope.com](http://www.viewsoniceurope.com)**

All rights reserved by ViewSonic Corporation. All other Corporate names and trademarks are the property of their respective companies. E&EO. All prices and specifications are subject to change without written notice. Images are for illustrative purpose only. Terms & Conditions Apply.